

REAL-EL

USER MANUAL



**PORTABLE SPEAKER SYSTEM
WITH BLUETOOTH**

X-747

Congratulations on your purchase of the REAL-EL speaker system!

COPYRIGHT

© 2022. ENEL GROUP OU.

This Manual and information contained in are copyrighted. All rights reserved.

TRADEMARKS

All trademarks are the property of their legal holders.

CONTENTS

1. BUYER RECOMMENDATIONS	1
2. PACKAGE CONTENTS	1
3. SAFETY PRECAUTIONS	2
4. TECHNICAL DESCRIPTION	2
5. CONNECTION AND OPERATION	3
6. TECHNICAL SPECIFICATIONS	4

1. BUYER RECOMMENDATIONS

- Unpack the device carefully. Make sure there are no accessories left in the box. Check up the device for damage; if the product was damaged during transportation, address the firm, which carried out the delivery; if the product functions incorrectly, address the dealer at once.
- Check up the package contents and availability of the warranty card.
- Do not switch on the speaker system immediately after you bring it into a room from environment with negative temperature! After unpacking, the speaker system should be kept in conditions of room temperature for at least 4 hours.
- Before installing and using the speaker system, read this Manual carefully and keep it for future reference.

2. PACKAGE CONTENTS

- Portable speaker system with Bluetooth — 1 pc
- 3.5 mm mini-jack to 3.5 mm mini-jack signal cable — 1 pc
- USB to USB Type C power cable — 1 pc
- User manual — 1 pc
- Warranty card — 1 pc

3. SAFETY PRECAUTIONS

- Do not open the portable speaker system (PSS) and do not perform repairs by yourself. Service and repairs should be performed only by qualified specialists at authorized service centers. The list of authorized service centers is on www.real-el.com
- Make sure that foreign objects do not get inside the holes of the PSS.
- Protect the PSS from high humidity, water and dust.
- Protect the PSS from heating: do not place it closer than 1 m from a heat source. Do not expose it to direct sunlight.
- Do not use any chemical agents for cleaning. Clean it with dry soft cloth only.
- In case of PSS does not work properly. Please contact place of purchase or service center.

Special features

- Bluetooth TWS
- Soft Bass beating
- Excellent Build Quality
- IPX 5 waterproof
- RGB Lighting
- Handsfree Microphone
- Bluetooth / Micro SD / Aux
- Voice assistant control
- EQ adjustment
- Built in Power bank

4. TECHNICAL DESCRIPTION

Control panel

- ① *USB port of Power Bank
- ② Charging DC 5V
- ③ AUX: 3.5 mm mini-jack for audio signal connecting (phone, MP3 player, etc.)
- ④ Micro SD card slot
- ⑤ RESET: Reset to factory settings
- ⑥ —: Previous track (long press in Player and Bluetooth mode; Volume decrease button (short press))
- ⑦ +: Next track (long press in Player and Bluetooth mode); Volume increase button (short press)
- ⑧ 🌞: Backlight ON/OFF
- ⑨ 🔋: Battery indicator
- ⑩ ▶: Play/Pause (Voice assistant control/Call control)
- ⑪ |||: EQ: Sound Effect mode
- ⑫ ∞+: TWS Connect an additional speaker (Bluetooth mode only)
- ⑬ ⏻: Power ON/OFF

*USB output is for power bank function only! Do not plug in USB flash!

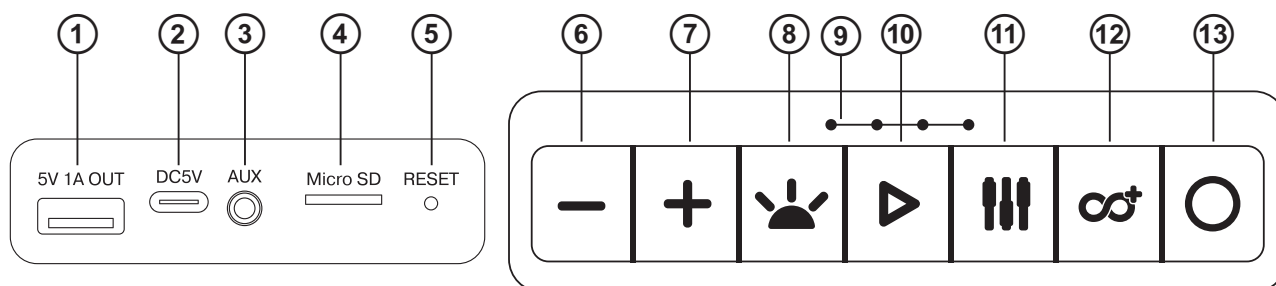

5. CONNECTION AND OPERATION

Charging the battery

- Before operation, fully recharge the battery. The charger is not included. Charge this device with a DC 5V universal charger with output current 2 A.
- Insert the charging cable into the charger connector, connect the other end to the charger, the charging indicator will be activated.

It is not recommended to leave the device for a long time connected to the charger after it is fully charged. Do not charge the speaker at low ambient temperatures. The minimum charge temperature is at least 10 °C.

Bluetooth mode

- Switch ON device with the **Ⓜ** button. The device will turn into search mode.
- Select a Bluetooth device search mode on the audio source (mobile phone, tablet, etc.). The display will show the name "REAL-EL X-747" which need to establish a connection with. After a successful connection, the loudspeaker will sound a signal.

TWS Bluetooth connection

- Turn on two identical REAL-EL X-747 systems and activate Bluetooth mode.
- On one system, press **Ⓜ** button, then the unit will switch to TWS mode. There will be a sound once two systems successfully connected.
- Connect a Bluetooth audio source to listen.
- To exit TWS mode, press **Ⓜ** button.

Activating Voice Assistant

- Make Bluetooth connection with your mobile phone.
- Long-press Play/Pause button to activate voice assistant.

The availability and name of the voice assistant depends on the operating system of your mobile device.

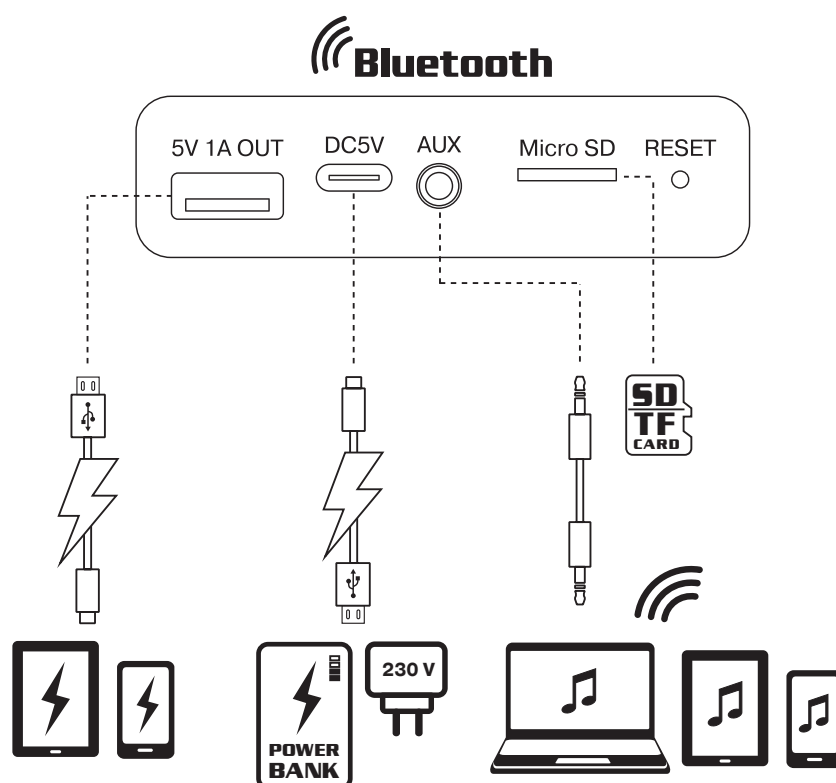

Hand-free call

- Under Bluetooth connection status, if there is an incoming call, short-press Play/Pause button to accept the call or long-press Play/Pause button to reject the call.
- During the call, long-press Play/Pause button to switch to talking on the phone.
- Short-press Play/Pause button or operate on mobile phone to end the call.

Reset

- If the speaker does not turn off or respond, user can short-press the Reset jack with a small round pin to reset the speaker.

Playback mode

- Insert a SD card drive into the corresponding slot, the audio track will be played automatically. In the playback mode, press the "+" or "-" button to select the desired tracks.
- Press the "▶" button to play or pause.

Note: During Bluetooth playback mode, if you insert a SD card, Bluetooth will be turned off and USB will play.

AUX mode

- For compatible music devices, use an audio cable with the 3.5 mm mini jack supplied in the box. Connect the cable to the audio input of the AUX and to any audio source with a 3.5 mm mini jack the screen will display LINE automatically.

Note: You must turn off the power button "OFF / ON." If the system is not used for a long time.

6. SPECIFICATION

Parameter	Value
Output power (RMS)	50 (2 x 25) W
Frequency range	70-20 000 Hz
Dimension of the speaker drivers	2 x Ø 89 mm
Supported Bluetooth Profiles	V 5.0 + BR + EDR / A2DP
Connection types	Bluetooth / Micro SD / Aux
Power supply	USB Type C / 5 V DC, 2 A
Battery	Lithium-ion 2*3600 mAh, DC 3.7 V
Bluetooth operation distance	up to 10 m
Case material	ABS plastic
Dimensions of the product	390 x 137 x 175 mm
Weight	3 kg

Notes:

- *Technical specifications given in this table are supplemental information and cannot give occasion to claims.*
- *Technical specifications and package contents are subject to change without notice due to the improvement of REAL-EL production.*



Manufacturer: ENEL GROUP OU, Harju maakond, Rae vald, Jüri alevik, Aruküla tee 55a, 75301, Estonia.
© Registered Trademark of ENEL GROUP OU. Estonia.